



## **BEL new 16" Pressure Vessel**

By Nadav Shachaf, BEL Group Limited

BEL Group Limited, a world leader in the design and manufacturing of pressure vessels, has developed a new *16" pressure vessel* able to accommodate 16" membranes provided by leading membrane producers.

*BEL's 16" pressure vessels*, named BEL16-S or BEL16-E series are available in Multiple / Side or End Port configurations. Side-ports are available (4" or 6" port diameter) for 300, 450, 600, 1000 & 1200 psi working pressure. Each vessel, like the BEL 8" series, can accommodate from 1 up-to 8 membranes.

This new *BEL 16" pressure vessel* brings important advantages and cost savings in Desalination & Reuse water plants.

The 16" vessel multiplies by 4 times the capacity in comparison to using 8" vessels in the same application.

With this solution, a plant could reduce the number of membranes, vessels, piping, and other accessories needed.



The unique design of *BEL's 16" pressure vessel* consists of a "steel free vessel body", also found in BEL 8" and 4" series. There is no use of any metal inserts embedded inside the glass fibers of the vessel body. The entire locking system is based on a support ring which is a separate part of the body and is replaceable. The locking groove is specially designed to accommodate the unique support rings and allows BEL to eliminate the need for inserting metal supports during the production process. The end result is a system that will not be subject to any internal corrosion at the sealing portion of the end plate, and is the safest system in the industry.



BEL 16" Pressure Vessels are designed, manufactured and tested according to the strict requirements of the Boiler and Pressure Code of the American Society of Mechanical Engineers ASME, section X, "Fiber Reinforced Plastic Pressure Vessels", the internationally recognized standard for composite pressure.

BEL, upon special request from IDE Technologies, Ltd., a world leader in the desalination market, designed a special feature on the *BEL 16" pressure vessel* that will allow the vessels to be aligned in a vertical position.



BEL designed a unique collar, which is an integral part of the pressure vessel body. The specially designed collar will support the vessel on a concrete platform in the plant.

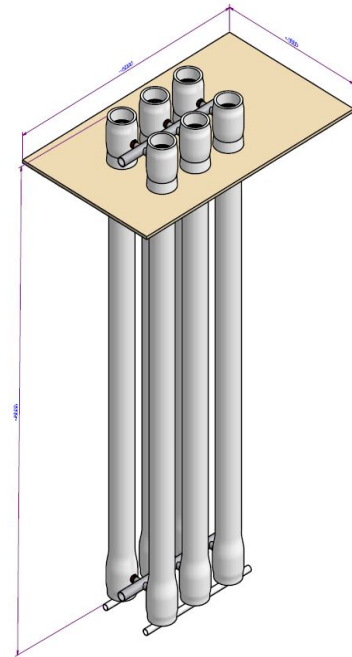

With this first time approach, BEL secured the order for more than 2,000, 16" pressure vessels, for IDE / Hutchison's SOREQ (150,000,000 Cubic meter per year) mega desalination plant that is now under construction.

BEL's scope of supply includes 1,200 psi, 1,000 psi, 600 psi and 450 psi 16" pressure vessels, for 8 X 16"/40" membranes. All vessels were supplied with 4" side ports.