

Notes:

1. All dimensions are for reference only, not for construction unless certified.
2. Item 17 & 18 should be located on feed side.
3. Drawing unit: mm. (inches)
4. Saddles can be shimmed if required.
5. Do not scale drawing, may be reprinted on any paper size or copied.
6. The vessel is supplied with two strap assembly.
7. Storage & installation: Indoor.
8. Vessel's Port diameters, according to ANSI Standards.

This drawing is an integral part of the general statement of use and Technical Manual

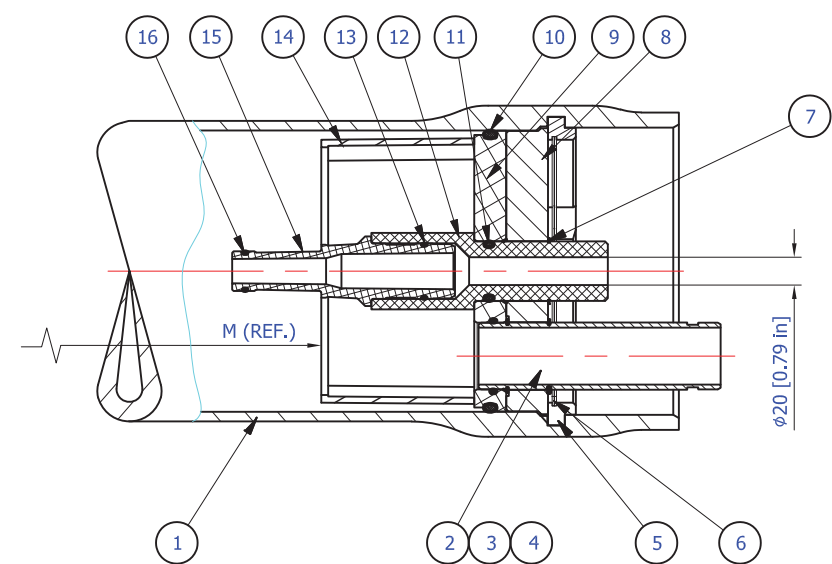

Warning.

1. Never pressurize a pressure vessel that was not loaded with membrane elements.
2. Wrong manifolding may cause an excessive pressure on port what can lead to leaks.
3. Max. allowable working pressure not to exceed 1800 psi. (124.1 bar).
4. Permeate internal pressure not to exceed 125 psi. (8.6 bar).
5. Operating temperature not to exceed 65°C (150°F).

Shell length code	L (l.o.a.)	S# (span)	M, mm/in length for membranes elements	W weight	Article number
	mm. inch	mm. inch		kg. lb.	
1	1622	710	1032	68	801800-1
	63.9	28	40.6	150	
2	2638	1550	2048	96	801800-2
	103.9	61	80.6	211	
3	3654	2550	3064	124	801800-3
	143.9	100	120.6	273	
4	4670	3250	4080	152	801800-4
	183.9	128	160.6	335	
5	5686	4250	5096	180	801800-5
	223.9	167	200.6	397	
6	6702	5250	6112	208	801800-6
	263.9	207	240.6	459	
7	7718	6250	7128	236	801800-7
	303.9	246	280.6	520	
8	8734	7250	8144	264	801800-8
	343.9	285	320.6	582	

Item	Q-ty	Part Number	Description	Material
1	1	801800-0	Body of Pressure Vessel	Glass/Epoxy, acc. F.I.202
2	2	009-150-1500	End Port 1.5"	Super duplex stainless steel
3	4	55412335	Retaining ring for SP	316 Stainless steel
4	2	55412225	Seal for endport	EPDM
5	2	005-816-1800	Support ring	316 Stainless steel
6	2	011-801-1202	Retaining ring (finger hook)	316 Stainless steel
7	2	283772336	Retaining ring for p.port	316 Stainless steel
8	2	283154220	Base plate	Aluminum
9	2	013-800-1201	Sealing plate	Engineering plastic
10	2	007-080-0092	Seal for sealing plate	EPDM
11	2	283776342	Seal for p. port	EPDM
12	2	008-801-0125	Permeate port 1.25" BSP	Engineering plastic
13	2	285773918	Seal for Adapter	EPDM
14	1	55410419	Thrust ring	Engineering plastic
15	2	As required	Adapter	Engineering plastic
16	2-4	As required	Membrane seal	EPDM
17	0-3	285779231	Disk spacer - 1mm	Engineering plastic
18	0-7	285779233	Disk spacer - 3mm	Engineering plastic
19	2	55410310	Strap Assy.	316 Stainless steel
20	2-3	55410351	Saddle	Engineering plastic

BEL TITLE: BEL8-E-1800 PSI (non code) RO PRESSURE VESSEL

DESIGN: DMG 21/03/2022
 CHECK: JME 21/03/2022
 APPR.: MAF 21/03/2022

DRAWING NO.: 8-E-1800

THIS DRAWING IS PROPERTY OF BEL GROUP LIMITED IT IS STRICTLY FORBIDDEN TO USE, COPY, REPRODUCE OR DISCLOSE ANY PART OF IT TO THIRD PARTY WITHOUT WRITTEN AUTHORIZATION.

REV.: 3



ORDER / R.F.Q. FORM - 8" END PORT PRESSURE VESSELS

Please fill and send it to your contact at BEL

P.O. / R.F.Q. Number:

Customer name:

1. NEW SYSTEM / EXISTING SYSTEM or Replacement , please provide details:

2. NUMBER OF VESSELS: Units

(Please use separate forms for each type in case of multi-type orders)

3. WORKING PRESSURE RATE (PSI): 1,800

4. NUMBER OF MEMBRANE ELEMENTS IN EACH VESSEL: (1,,,,,,8)

5. MEMBRANE BRAND AND TYPE:

(Please add membrane data sheet)

6. CONFIRM TYPE: BEL8-E- - M *Vessel's Port diameters, according to ANSI Standards.*
Pressure # of membranes

7. PERMEATE PORTS OUTLET: 1.25" BSP male

8. ADAPTERS OPTIONS: Two Standard adapters Standard & Solid (blind) adapter

9. COLOR: Standard (white, RAL 9010) Other RAL number: *(contact for pricing)*

Customer signature:

Date:

FOR DETAILS PLEASE VISIT OUR WEBSITE: www.belvessels.com

May, 2020