

Notes:

1. All dimensions are for reference only, not for construction unless certified.
2. For membranes shimming (if needed) use disks spacers (item 17 & 18) on feed side of the vessels.
3. Drawing unit: mm. (inches)
4. Saddles can be shimmed if required.
5. Do not scale drawing, may be reprinted on any paper size or copied.
6. The vessel is supplied with two strap assembly.
7. * - ASME parts.
8. Storage & installation: Indoor.
9. Vessel's Port diameters, according to ANSI Standards.

This drawing is an integral part of the general statement of use and Technical Manual

Shell length code	L (l.o.a.) mm. inch	S# (span) mm. inch	M, mm/in length for membranes elements	W weight kg. lb.	Article number
1	1446	710	1022	29	80450-1-A
	56.9	28	40.2	63	
2	2462	1550	2038	40	80450-2-A
	96.9	61	80.2	87	
3	3478	2550	3054	50	80450-3-A
	136.9	100	120.2	111	
4	4494	3250	4070	61	80450-4-A
	176.9	128	160.2	135	
5	5510	4250	5086	72	80450-5-A
	216.9	167	200.2	159	
6	6526	5250	6102	83	80450-6-A
	256.9	207	240.2	182	
7	7542	6250	7118	94	80450-7-A
	296.9	246	280.2	206	
8	8558	7250	8134	104	80450-8-A
	336.9	285	320.2	230	

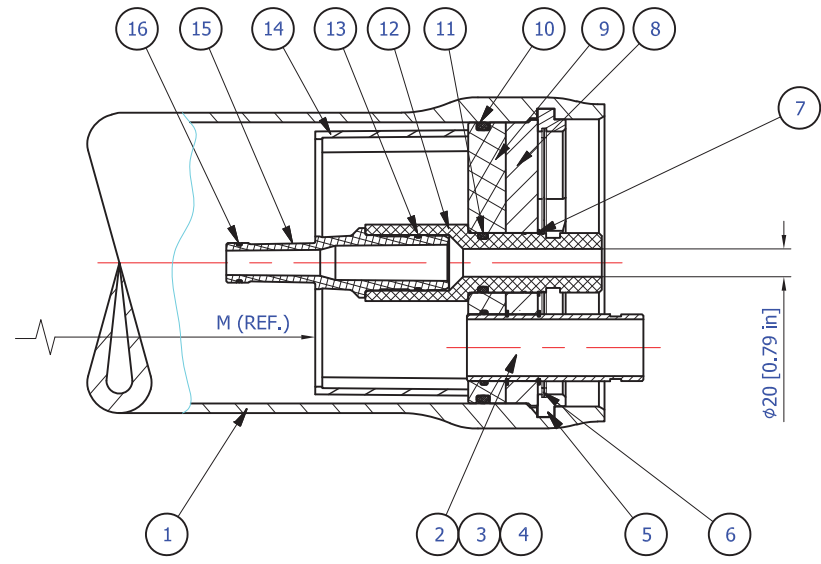

Warning.

1. Never pressurize a pressure vessel that was not loaded with membrane elements.
2. Wrong manifolding may cause an excessive pressure on port what can lead to leaks.
3. Max. allowable working pressure not to exceed 450 psi. (31 bar).
4. Permeate internal pressure not to exceed 125 psi. (8.6 bar).
5. Operating temperature not to exceed 65°C (150°F).

Item	Q-ty	Part Number	Description	Material
1*	1	80450-0	Body of Pressure Vessel	Glass/Epoxy
2*	2	009-150-0452	End Port 1.5"	316 Stainless steel
3	4	55412335	Retaining ring for port	316 Stainless steel
4	2	55412225	Seal for endport	EPDM
5*	2	55410299	Support ring	Aluminum
6	2	011-801-1202	Retaining ring (finger hook)	316 Stainless steel
7	2	283772336	Retaining ring for p.port	316 Stainless steel
8*	2	003-861-0600	Base plate	Aluminum
9	2	013-800-1201	Sealing plate	Engineering plastic
10	2	007-080-0092	Seal for sealing plate	EPDM
11	2	283776342	Seal for p. port	EPDM
12	2	008-801-0125	Permeate port 1.25" BSP	Engineering plastic
13	2	285773918	Seal for Adapter	EPDM
14	1	55410419	Thrust ring	Engineering plastic
15	2	As required	Adapter	Engineering plastic
16	2-4	As required	Membrane seal	EPDM
17	0-3	285779231	Disk spacer - 1mm	Engineering plastic
18	0-7	285779233	Disk spacer - 3mm	Engineering plastic
19	2	55410310	Strap Assy.	316 Stainless steel
20	2-3	55410351	Saddle	Engineering plastic

	TITLE	BEL8-E-450 psi. - code RO PRESSURE VESSEL	DESIGN	DMG	04/05/2020
	DRAWING NO.	BEL8-E-450-A	CHECK	JME	04/05/2020
			APPR.	MAF	04/05/2020
THIS DRAWING IS PROPERTY OF BEL GROUP LIMITED IT IS STRICTLY FORBIDDEN TO USE, COPY, REPRODUCE OR DISCLOSE ANY PART OF IT TO THIRD PARTY WITHOUT WRITTEN AUTHORIZATION.					REV.: 7



ORDER / R.F.Q. FORM - 8" END PORT PRESSURE VESSELS

Please fill and send it to your contact at BEL

P.O. / R.F.Q. Number:

Customer name:

1. NEW SYSTEM / EXISTING SYSTEM or Replacement , please provide details:

2. NUMBER OF VESSELS: Units

(Please use separate forms for each type in case of multi-type orders)

3. WORKING PRESSURE RATE (PSI): 300 450 600 1,000 1,200 1,500

4. NUMBER OF MEMBRANE ELEMENTS IN EACH VESSEL: (1,,,,,8)

5. MEMBRANE BRAND AND TYPE:

(Please add membrane data sheet)

6. CONFIRM TYPE: BEL8-E- - M Vessel's Port diameters, according to ANSI Standards.
Pressure # of membranes

7. PERMEATE PORTS OUTLET: 1.25" BSP male

8. ASME code SEC. X, RP stamped vessel: NO YES *(please contact for pricing)*

9. ADAPTERS OPTIONS: Two Standard adapters Standard & Solid (blind) adapter

10. COLOR: Standard (white, RAL 9010) Other RAL number: *(contact for pricing)*

Customer signature:

Date:

FOR DETAILS PLEASE VISIT OUR WEBSITE: www.belvessels.com

May, 2020